

REVISIONS			
REV	DESCRIPTION	DATE	APPROVED
1	WAS CLOSED TOOL	3/22/11	TMD

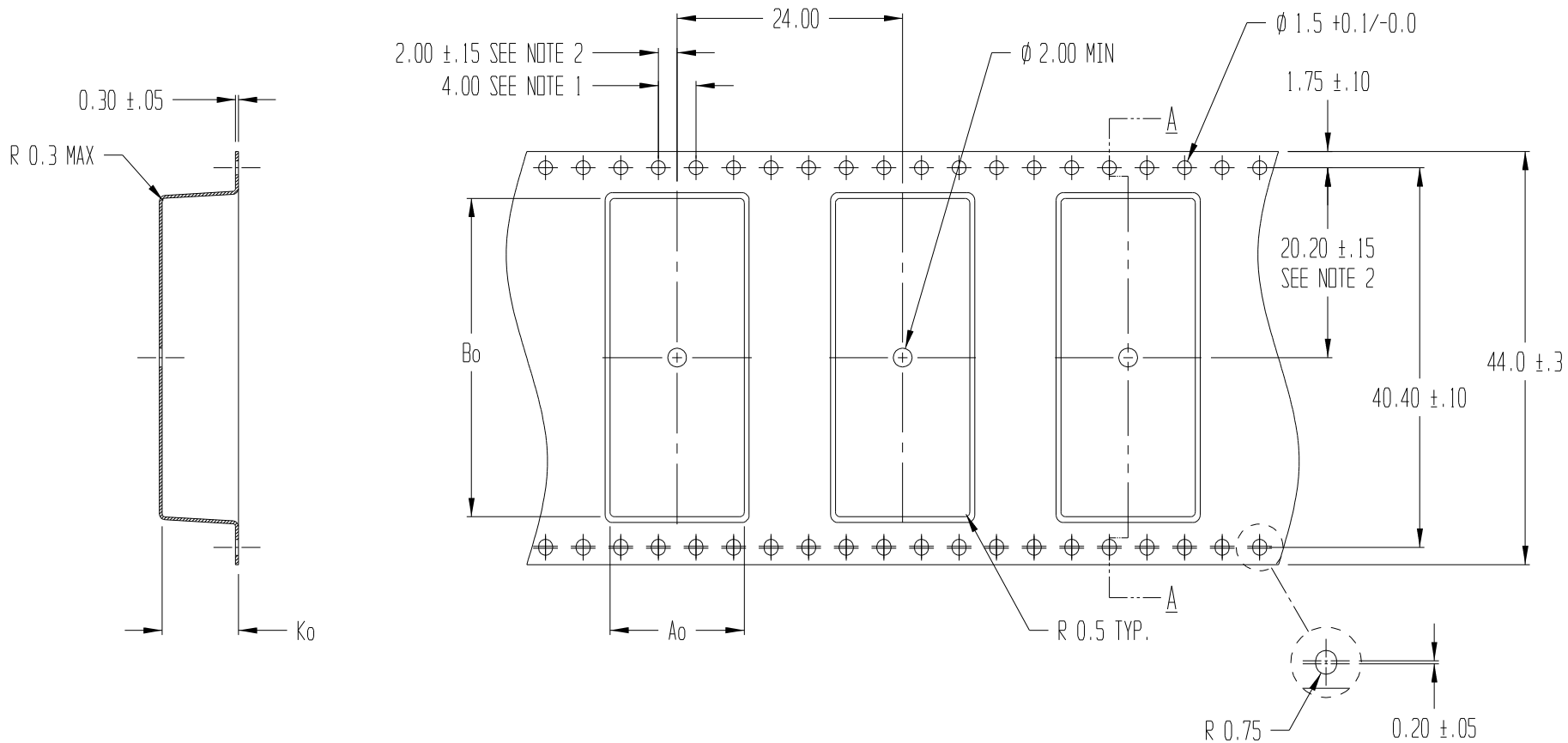

SECTION A - A

Ao = 14.3  
Bo = 33.9  
Ko = 8.1

NOTES:

1. 10 SPROCKET HOLE PITCH CUMULATIVE TOLERANCE  $\pm 0.2$
2. POCKET POSITION RELATIVE TO SPROCKET HOLE MEASURED AS TRUE POSITION OF POCKET, NOT POCKET HOLE
3. Ao AND Bo ARE CALCULATED ON A PLANE AT A DISTANCE "R" ABOVE THE BOTTOM OF THE POCKET.



**ADVANTEK**<sup>®</sup>  
engineered confidence™

TITLE ADVANTEK PART DRAWING NUMBER FG0001-A CARRIER TAPE			
TOLERANCES - UNLESS NOTED 1PL $\pm 0.2$ 2PL $\pm 0.10$	MATERIAL PS+C	DWG SIZE B	
ALL DIMS IN MILLIMETERS PER ASME Y14.5M			
DRAWN BY TMD	DATE 02/24/2003	SCALE 2:1	SHEET 1 OF 1
CK'D BY	PROJECT NO. T-12153 / 7666.00	DWG NO. T104067BT	REV 1