

REVISIONS			
REV	DESCRIPTION	DATE	APPROVED
1	WAS CLOSED TOOL	4/18/11	TMD

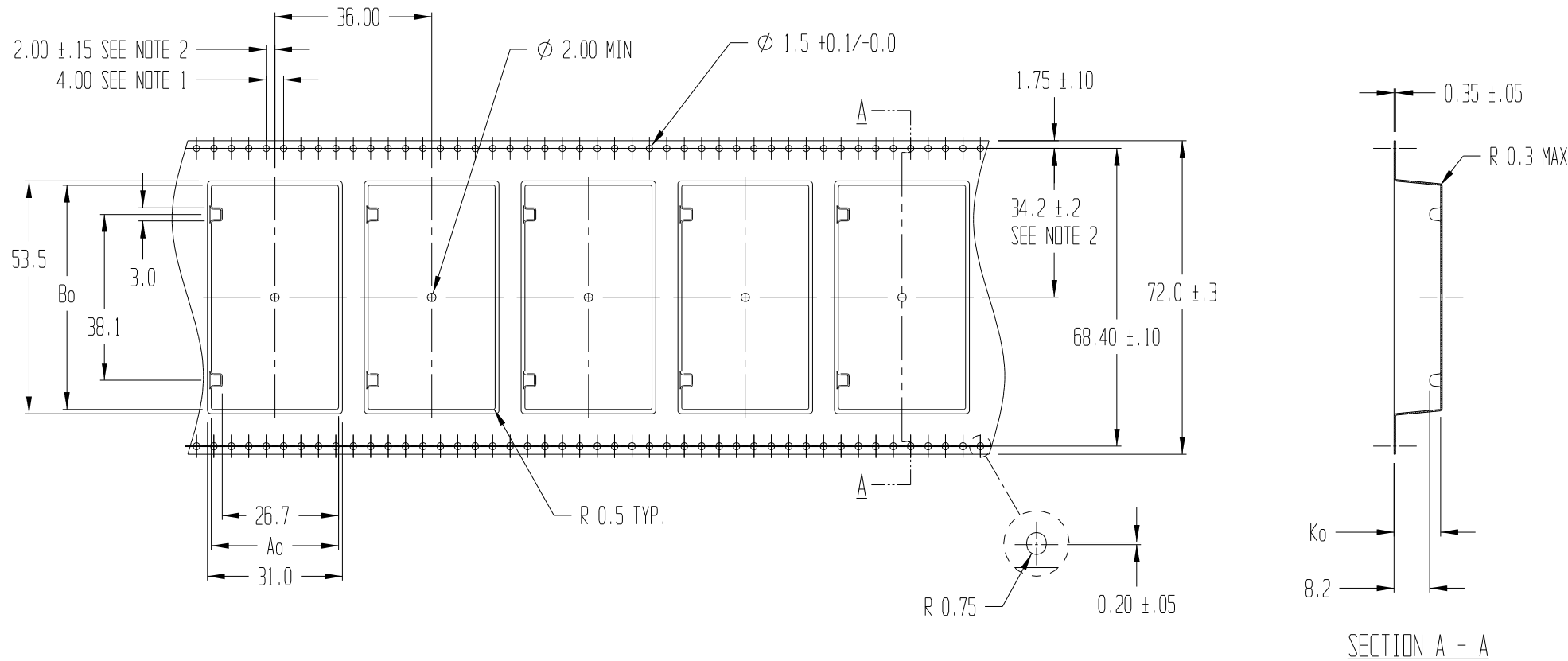

Ao = 29.2
Bo = 51.5
Ko = 10.7

NOTES:

1. 10 SPROCKET HOLE PITCH CUMULATIVE TOLERANCE ±0.2
2. POCKET POSITION RELATIVE TO SPROCKET HOLE MEASURED AS TRUE POSITION OF POCKET, NOT POCKET HOLE
3. Ao AND Bo ARE CALCULATED ON A PLANE AT A DISTANCE "R" ABOVE THE BOTTOM OF THE POCKET.



ADVANTEK[®]
engineered confidence™

TITLE ADVANTEK PART DRAWING NUMBER MS1001-A CARRIER TAPE			
TOLERANCES - UNLESS NOTED 1PL ±.2 2PL ±.10	MATERIAL PS+C	DWG SIZE B	
ALL DIMS IN MILLIMETERS PER ASME Y14.5M			
DRAWN BY RVR	DATE 03/22/2001	SCALE 1:1	SHEET 1 OF 1
CK'D BY	PROJECT NO. T-10958 / 7666.00	DWG NO. T103247BT	REV 1