

REVISIONS			
REV	DESCRIPTION	DATE	APPROVED
1	WAS CUSTOM TOOL	9/02/11	VAW

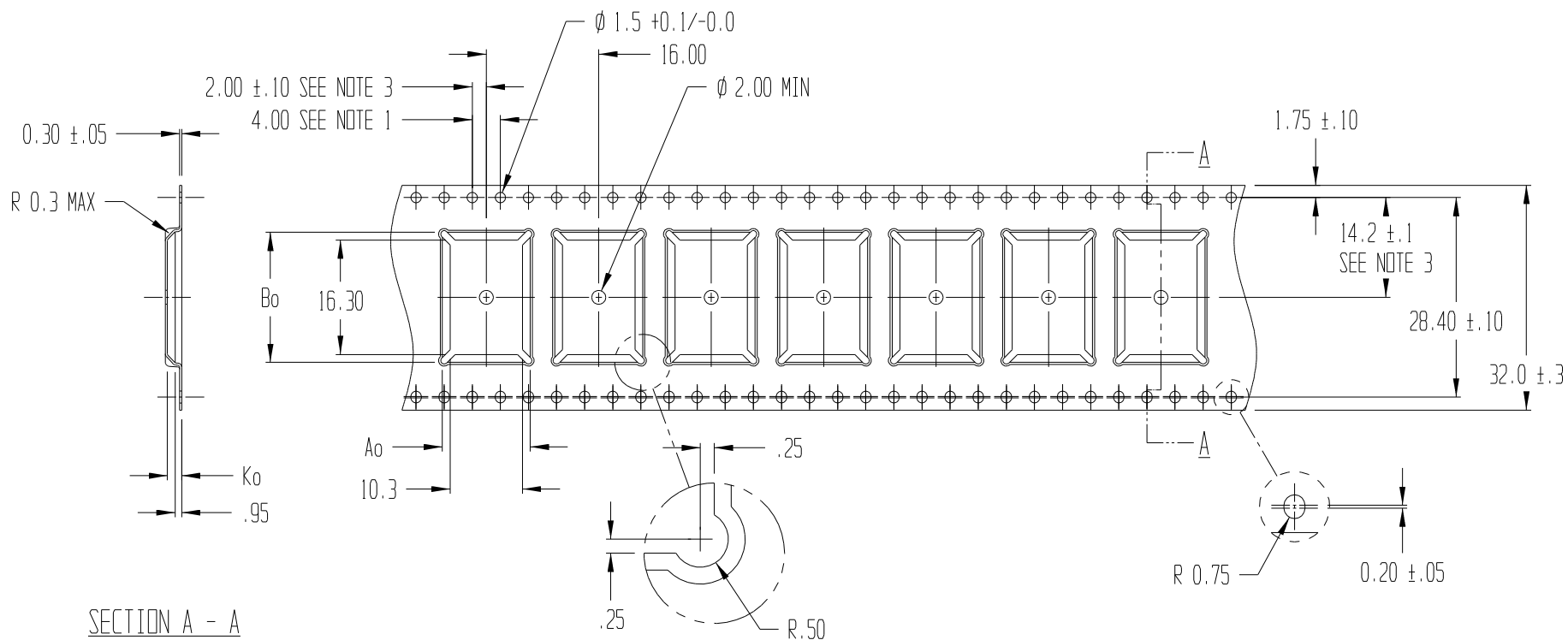

SECTION A - A

$A_0 = 12.50$
 $B_0 = 18.50$
 $K_0 = 2.05$

NOTES:

1. 10 SPROCKET HOLE PITCH CUMULATIVE TOLERANCE ± 0.2
2. CAMBER IN COMPLIANCE WITH EIA 481
3. POCKET POSITION RELATIVE TO SPROCKET HOLE MEASURED AS TRUE POSITION OF POCKET, NOT POCKET HOLE
4. A_0 AND B_0 ARE CALCULATED ON A PLANE AT A DISTANCE "R" ABOVE THE BOTTOM OF THE POCKET.



TITLE ADVANTEK PART DRAWING NUMBER LAC064-B CARRIER TAPE			
TOLERANCES - UNLESS NOTED 1PL ± 0.2 2PL ± 0.10	MATERIAL PS+C	ALL DIMENSIONS IN MILLIMETERS DWG SIZE B	
DRAWN BY BTH	DATE 2/21/03	SCALE 3:2	SHEET 1 OF 1
REFERENCE NO. T-11805-A/7667.00	DWG NO. T104036BT	REV 1	