

REVS				
REV.	DESCRIPTION	DATE	GS#	APPROVED
3	ADD MATERIAL TABLE	6/15/2016	6/15/2016	XHL

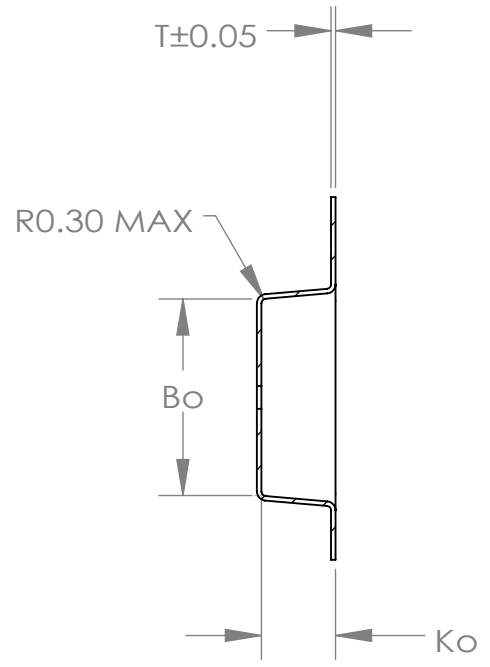

SECTION B-B

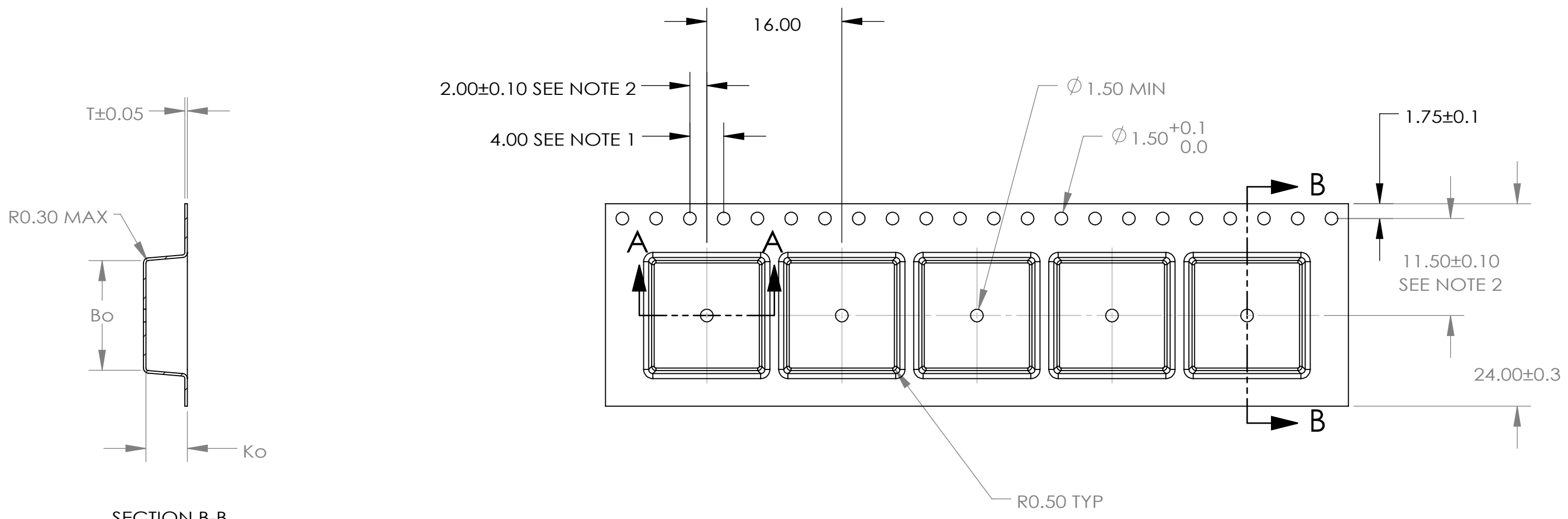
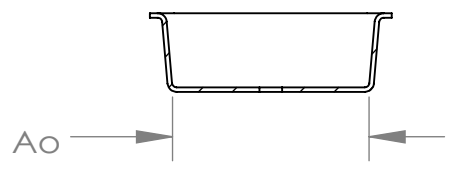

SECTION A-A

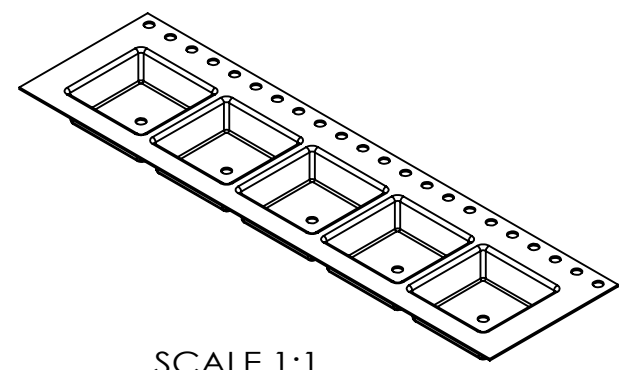

SCALE 1:1

	DIM	±
Ao	13.00	0.1
Bo	13.00	0.1
Ko	4.90	0.1

3

Part #	Material	T	DWG #
PLCC28-AC	PS+C	0.30	A0103-89-4
PLCC28-AX	PS+C	0.35	A1128-90-5

- NOTES:
- 10 SPROCKET HOLE PITCH CUMULATIVE TOLERANCE  $\pm 0.2$
  - POCKET POSITION RELATIVE TO SPROCKET HOLE MEASURED AS TRUE POSITION OF POCKET, NOT POCKET HOLE.
  - Ao AND Bo ARE MEASURED ON A PLANE AT A DISTANCE "R" ABOVE THE BOTTOM OF THE POCKET.

THE INFORMATION CONTAINED IN THIS DRAWING IS THE SOLE PROPERTY OF ADVANTEK INC. ANY REPRODUCTION IN PART OR WHOLE WITHOUT THE WRITTEN PERMISSION OF ADVANTEK INC. IS PROHIBITED.



TITLE: ADVANTEK PART DRAWING NUMBER PLCC28-A  
CARRIER TAPE

TOLERANCES UNLESS - SPECIFIED 1 PL $\pm 0.2$ 2 PL $\pm 0.10$	MATERIAL SEE TABLE	APPROVED BY: JH		
CAD GENERATED DRAWING, DO NOT MANUALLY UPDATE DO NOT SCALE DRAWING	DRAWN BY: XHL	DATE 6/15/2016	SCALE 2:1	SHEET 1 OF 1
	PROJECT #	DRAWING # SEE TABLE		SIZE B
				REV. 3