

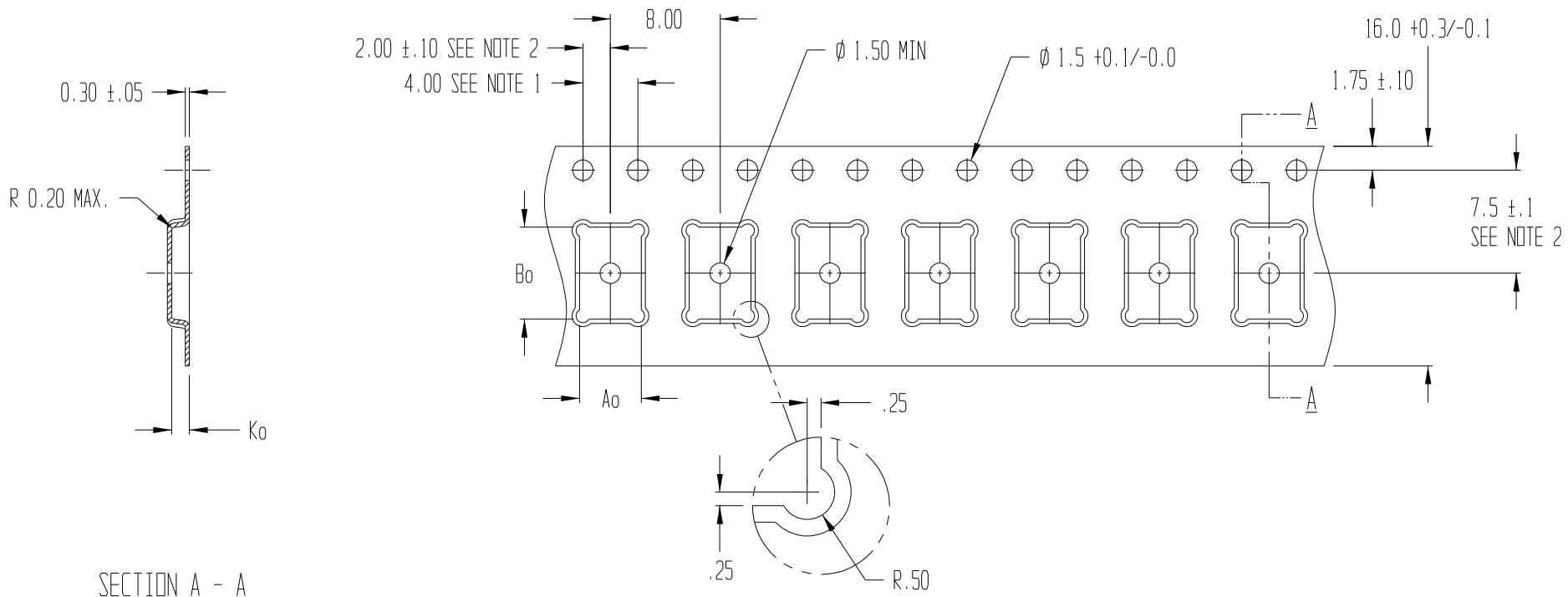

REVISIONS			
REV	DESCRIPTION	DATE	APPROVED



$A_0 = 4.50$   
 $B_0 = 6.70$   
 $K_0 = 1.30$

- NOTES:
1. 10 SPROCKET HOLE PITCH CUMULATIVE TOLERANCE  $\pm 0.2$
  2. POCKET POSITION RELATIVE TO SPROCKET HOLE MEASURED AS TRUE POSITION OF POCKET, NOT POCKET HOLE
  3.  $A_0$  AND  $B_0$  ARE CALCULATED ON A PLANE AT A DISTANCE "R" ABOVE THE BOTTOM OF THE POCKET.

 <b>ADVANTEK</b> <sup>®</sup> engineered confidence™			
TITLE ADVANTEK PART DRAWING NUMBER CCA088-A CARRIER TAPE			
TOLERANCES - UNLESS NOTED 1PL $\pm .2$ 2PL $\pm .10$	MATERIAL PS+C	DWG SIZE B	
ALL DIMS IN MILLIMETERS PER ASME Y14.5M 			
DRAWN BY BTH	DATE 12/28/2012	SCALE 3:1	SHEET 1 OF 1
CK'D BY	PROJECT NO. 10482.00	DWG NO. T110261BT	REV